

STRUCTURAL ENGINEER'S REPORT
ON
THE DEMOLITION
OF
THE LATHBURY WATCH TOWER,
WINDMILL HILL ROAD.



CONTENTS		Page
1.0	INTRODUCTION.	2
	1.1 Scope of Works.	
	1.2 Location.	
	1.3 General Background Information & Construction	
2.0	SURVEY RESULTS.	3
	2.1 Visual Survey.	
3.0	SUROUNING AREAS AND BUILDINGS.	4
4.0	DEMOLITION METHODOLOGY.	5
	4.1 Demolition Sequence.	
	4.2 Legislation.	
	4.3 Designer's Risk Assessments.	
APPENDIX A	- LOCATION AND SITE PLAN	
APPENDIX B	- DEMOLITION PLANT	
APPENDIX C	- PLATES	
APPENDIX D	- DESIGNER'S RISK ASSESSMENTS	
APPENDIX E	- TRAFFIC MANAGEMENT PLAN	

1.0 INTRODUCTION.

1.1 Scope of Works.

In April 2014, JJ De La Paz Consulting Engineers Ltd. was commissioned by Monteverde & Sons Ltd, to develop a methodology for the demolition of the Lathbury Barracks Watch Tower. This would require an external survey to be undertaken of the building to establish the structural type and condition of the building and to assess the stability and integrity of parts of the structure during the demolition.

Part of the brief also includes undertaking a visual survey of the surrounding land, services and buildings that may be affected by the demolitions.

1.2 Location.

The Lathbury Watch Tower is located on Windmill Hill Road. Refer to the location and site plan contained in Appendix A.

1.3 General Background Information.

The Lathbury Watch Tower was built by the British Military during the second world war. The building has been derelict for the past 10-15 years. There are no existing record drawings.

Monteverede & Sons Ltd, through GJBS, has been commissioned by the Gibraltar Government to demolish the buildings to ground level.

Reference can be made to the various elevations plates in Appendix C

2.0 STRUCTURAL SURVEY.

2.1 Visual Survey.

The watch tower building is currently surrounded with scaffolding and works are progressing to strip the asbestos containing paint off the external walls. Therefore, a close inspection has not been undertaken. However, it has been possible to determine that the main tower is a three storey building comprising load bearing masonry walls supporting reinforced concrete floors and roof slab.

The adjacent buildings to be demolished are single storey and comprise load bearing masonry walls supporting a reinforced concrete roof slab.

It is very likely that the structural masonry walls are founded on strip footings which bear directly onto the underlying rock.

3.0 SURROUNDING AREAS AND BUILDING.

Reference Site Plan contained in Appendix A.

There is a busy highway, Windmill Hill Road, which runs close to the building site. This is the main access road to the Cliff Tops Residential block, the Prison, the Industrial Park and the Upper Rock. It is envisaged that the road will have to be temporarily closed to traffic and pedestrians whilst the watch tower building is demolished.

The watch tower is built within the old gun battery which overlooks the Lathbury Barracks Parade Ground.

An MOD Facility is situated at the foot of the gun battery. The Contractor needs to contact the MOD to ensure that the facility is not occupied during the demolition of the main watch tower demolition works.

4.0 DEMOLITION METHODOLOGY.

4.1 DEMOLITION SEQUENCE.

Prior to the start of the works the demolition sub-contractor shall submit sufficient documentation to demonstrate that they are experienced and competent in carrying out demolitions. The above contractors shall also demonstrate that they have undertaken the necessary risk assessments and submit these to the Structural Engineer / PM together with their method statement prior to commencing work on site. These should detail the traffic management, security arrangements and protection measures following the recommendations given in this report.

The Structural Engineer will be present on site at key stages to ensure that the demolition procedure follows the methodology outlined below.

The demolitions will be carried out in the following sequence:

- a) Ensure all services are scanned, disconnected and protected;
- b) The contractor should undertake a dilapidation survey of the area;
- c) Erect site fencing with debris netting around the perimeter of the site prior to starting the structural demolition works;
- d) Remove all identified asbestos and contaminated materials by specialist contractor (not covered in this report);
- e) Traffic Management to be implemented at the site entrance / egress point, off Windmill Hill Road, to safeguard pedestrians along the footpath and to provide safe access to construction traffic off and onto the busy highway where the sightline is poor;
- f) Remove all soft strip materials, including windows, doors, plasterboard partitions, roof pipes, gutters, water tanks, etc..., using safe scaffolding access.

- g) Commence demolition of the eastern single story building by specialist contractor, with a 360 Excavator PW200-7 (refer to Appendix B) working from the site entrance point and advancing slowly into the site in a north westerly direction, ensuring that the building is demolished inwards and away from the cliff edge. It is anticipated that the excavator will use a breaker at the end of its dipper arm for the majority of the demolition, and occasionally change to a crusher attachment as and when required. Ensure that the demolition proceeds from top to bottom, taking care not to leave any unsupported walls during the demolition process. Hosing down during the demolition will help to contain the dust. Care must be taken not to damage the adjacent gun battery walls and the adjacent road surfacing.
- h) Once the single story building has been demolished to ground level, the rubble will be moved on to tipper trucks parked within the site boundary and transferred to the local rubble tip.
- i) Prior to advancing to the Watch Tower, set up the temporary traffic management plan as indicated in Appendix C. The Contractor will have to apply to the Highways Authority for the temporary closure of the section of Windmill Hill Road just below the site location (highlighted in red). Alternative access arrangement for the Prison, Industrial Park, Upper Rock and Cliff Tops, can be arranged via Engineer's Road (highlighted in yellow). Access to Sunrise Close and Buffadero will remain via Windmill Hill Road.
- j) Commence demolition of the Watch Tower building by specialist contractor, with a 360 Excavator PW200-7 (refer to Appendix B) working in a north westerly direction, ensuring that the building is demolished inwards and away from the cliff edge. It is anticipated that the excavator will use a breaker at the end of its dipper arm for the majority of the demolition, and occasionally change to a crusher attachment as and when required. Ensure that the demolition proceeds from top to bottom, taking care not to leave any unsupported walls during the demolition process. Hosing down during the demolition will help to contain the dust. Care must be taken not to damage the adjacent gun battery walls and the adjacent road surfacing.
- k) Once the Watch Tower building has been demolished, Windmill Hill Road can be re-opened. The area is to be made good as instructed by the PM.

4.2 LEGISLATION.

The main contractor shall comply with the following building regulations and ensure that all subcontractors are made aware of their obligations for compliance:

- Institution of Civil Engineers Demolition Protocol;
- The Environmental Protection Act, 1990;
- The Control of Pollution Act, 1990;
- The Construction CDM Regulations, 1998;
- The Control of Asbestos at Work Regulations, 2006;
- The Asbestos (Licensing) Regulations, 1998;
- The Control of Lead at Work Regulations, 1998;
- Health and Safety at Work Regulations, 1999;
- The Noise at Works Regulation, 1989;
- The Provision of Work Equipment Regulations, 1992;
- The Health and Safety (First Aid) Regulations, 1981;
- The Manual Handling Operations Regulations, 1992.

4.3 DESIGNER'S RISK ASSESSMENT.

The Contractor Shall submit detailed written statements to indicate specifically how the risks are mitigated on site, in respect of the designer's risk assessments contained in Appendix D.

Main Risk Items:

- Live Services;
- Asbestos &/or Hazardous Material;
- Temporary Works;
- Work at Height;
- Roof Work;
- Demolition;
- Manual Handling.

APPENDIX A

SITE & LOCATION PLAN



APPENDIX B

DEMOLITION PLANT

KOMATSU

PW200-7

ENGINE POWER
134 kW / 180 HP @ 2.000 rpm

OPERATING WEIGHT
18.970 - 22.100 kg

BUCKET CAPACITY
max. 1,58 m³

PW
200

HYDRAULIC WHEELED EXCAVATOR



PW200-7

WALK-AROUND

The PW200-7 is a rugged, productive, all-European machine. Designed and expressly built for European markets, it delivers productivity, reliability and operator comforts in a robust, environmentally-friendly package. Komatsu's exclusive, on-board, HydraMind system assists in all operations, providing enhanced machine performance that's always perfectly matched to the task.

Advanced Attachment Control

The PW200-7 is equipped to handle a wide variety of attachments. The advanced attachment control system features:

- Operator selectable hydraulic flow control
- Adjustable presets for rapid attachment changeover
- Attachment piping options for breaker, clamshell or crusher

Undercarriage

- Designed for high ground clearance
- Virtually zero axle rocking with out-board wet disc system
- Powerful drawbar pull
- Automatic 3-speed travel
- 35 km/h maximum travel speed
- Optional undercarriage width: 2,75 m



Komatsu Tracking System

Track and monitor your machine anytime, anywhere for total peace of mind.

High productivity

- High lifting capacity and good stability
- High drawbar pull
- Large bore bucket cylinders can be installed to the 1,8 m and 2,4 m arms to greatly increase digging forces and productivity in tough conditions.

Excellent reliability and durability

- Reliable major components designed and built by Komatsu
- Exceptionally reliable electronic devices



SpaceCab™

- Sealed and pressurised cab with standard climate control
- Low-noise design
- Low-vibration design with viscous cabin damper mounting
- Cab moved forward for better visibility
- Ergonomic control levers
- Seat specially designed for wheeled machines, with exceptional extra comfort

In harmony with the environment

- The economy mode reduces fuel consumption
- Low operating noise
- Designed for easy end-of-life recycling

ENGINE POWER
134 kW / 180 HP

OPERATING WEIGHT
18.970 - 22.100 kg

BUCKET CAPACITY
max. 1,58 m³



The Komatsu SAA6D107E-1 engine meets EU Stage IIIA and EPA Tier III emission regulations.



EMMS

EMMS (Equipment Management and Monitoring System)

The EMMS is a highly sophisticated system, controlling and monitoring all the excavator functions. The user interface is highly intuitive and provides the operator with easy access to a huge range of functions and operating information.

Four working modes

The PW200-7 is equipped with three working modes: (P, E, B), plus a lifting mode (L). Each mode is designed to match the engine speed, pump speed, and system pressure with the current operating requirement. This provides the flexibility to match equipment performance to the job at hand.

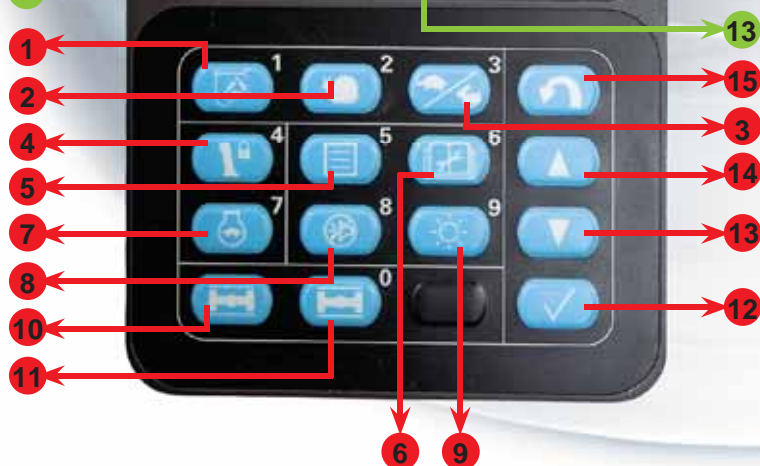
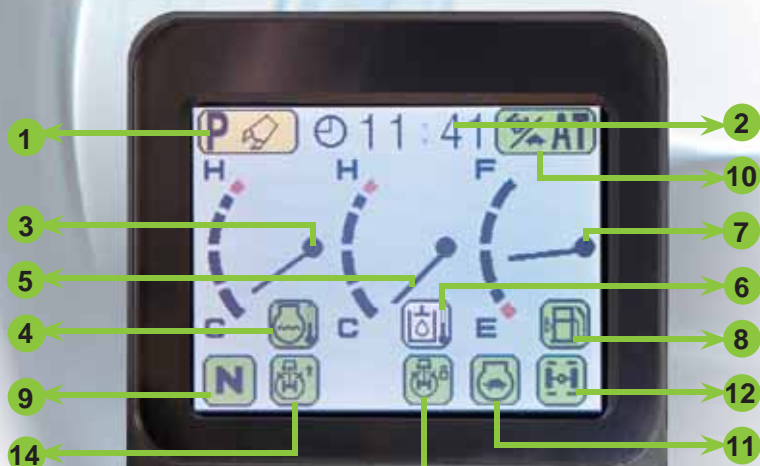

On-screen symbols

- 1 Working mode
- 2 Service meter and clock
- 3 Engine water gauge
- 4 Engine water temperature warning
- 5 Hydraulic oil gauge
- 6 Hydraulic oil temperature warning
- 7 Fuel gauge
- 8 Fuel low level warning
- 9 Travel direction
- 10 Travel mode
- 11 Auto deceleration
- 12 Suspension lock
- 13 Swing lock
- 14 Swing position

Push-button control switches

- 1 Working mode select
- 2 Creep speed
- 3 High/low speed select
- 4 Control lever lock
- 5 Menu select key
- 6 Service menu
- 7 Engine auto deceleration
- 8 Buzzer cancel
- 9 Brightness adjust
- 10 Suspension auto lock
- 11 Suspension lock
- 12 Accept key
- 13 Scroll down
- 14 Scroll up
- 15 Undo switch
- 16 Rear left outrigger/blade
- 17 Front left outrigger/blade
- 18 Front right outrigger
- 19 Rear right outrigger

Power mode

For maximum power and fast cycle times. Normally used for heavy operations such as hard digging and loading. This mode allows access to the 'PowerMax' function to temporarily increase the digging force by 7% for added power in tough situations.

Economy mode

The environmentally-friendly mode. For running more quietly during operations at night and/or in urban areas. Fuel consumption and exhaust emissions are reduced.

Breaker mode

Delivers optimal hydraulic pressure, flow and engine RPMs for powerful breaker operations.

Lifting mode

Increases the lifting capacity 7% by raising the hydraulic pressure. This mode supports safe lifting operations.

Working mode	Application	Advantage
P	Power mode	<ul style="list-style-type: none"> • Maximum production/power • Fast cycle times
E	Economy mode	<ul style="list-style-type: none"> • Excellent fuel economy
B	Breaker mode	<ul style="list-style-type: none"> • Optimum engine RPMs and hydraulic flow
L	Lifting mode	<ul style="list-style-type: none"> • Hydraulic pressure has been increased by 7%



Hydraulic flow general adjustment screen in B (breaker) mode



Fine tune hydraulic flow adjustment screen in B (breaker) mode



Fine tune hydraulic flow adjustment screen in P (power) or E (economy) mode



Password screen

Easy to see and easy to use

Superb recognition colour LCD screens for each mode. Letters and numbers are combined with colour images for exceptionally clear and easy-to-read information. The high-resolution screen is easy to read in bright sunlight and in all lighting conditions.

Automatic three-speed travel

The travel speed is automatically shifted from high to low speed, according to the ground conditions.

	High	Low	Auto	Creep
Travel speed	35 km/h	9 km/h	0 - 35 km/h	1,5 km/h

Fingertip hydraulic pump oil flow adjustment

From the LCD monitor, you can automatically select the optimal hydraulic pump oil flow for breaking, crushing, and other operations in the B, P or E modes. Also, when simultaneously operating with attachments and work equipment, the flow to the attachment is reduced automatically, thus delivering a smooth movement of the work equipment.

Password protection

Prevents unauthorised machine use or transport. The engine cannot be started without your four-digit use or password.

For total security, the battery is connected directly to the starter motor. Both the starter and the engine need the password.

The password can be activated and deactivated upon request.

WORKING ENVIRONMENT

PW200-7's cab interior is spacious and provides a comfortable working environment...

SpaceCab™

Comfortable cab

The new PW200-7 inner cab volume is 14% greater than the Dash 6 models, offering an exceptionally comfortable operating environment. The large cab enables the seat, with headrest, to be reclined to horizontal.

Pressurised cab

The standard-equipped climate control, air filter and a higher internal air pressure resist dust entry into the cab.

Low-noise design

Noise levels are substantially reduced; engine noise as well as swing and hydraulics operations noise.

Cab damper mounting for low vibration levels

PW200-7 uses a new and improved viscous damping cab mount system that incorporates a longer stroke plus an added spring. The new cab damper mounting, combined with strengthened left and right-side decks, aids the reduction of vibrations to the operator's seat.

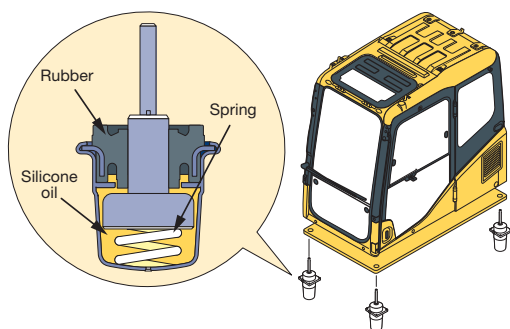

Outer air filter

Easy removal/installation of the air conditioner filter element, without tools facilitates easier cleaning.



Large sun roof with integrated sun shade



12-Volt power supply and (optional) radio cassette



Climate control



Tiltable steering wheel with several functions; wiper control, indicator, horn, and head lights

Safety features

Multi-position controls

The multi-position, proportional pressure control levers allow the operator to work in comfort whilst maintaining precise control. A double-slide mechanism allows the seat and controllers to move together, or independently, allowing the operator to position the controllers for maximum productivity and comfort.



Hot and cool box



Joysticks with proportional control button for attachments



Seat sliding range: 340 mm



Defroster/demister

Improved, wide visibility

The right side window pillar has been removed and the rear pillar reshaped to provide greater visibility. Blind spots have been decreased by 34%.

Pump/engine room partition

This prevents hydraulic oil from spraying onto the engine to reduce the risk of fire.

Thermal and fan guards

Are placed around high-temperature parts of the engine.

Steps with non-skid surface and large handrail

Steps with non-slip surfacing ensure safer maintenance.

Thermal guard



Non-slip sheet



Large handrail for safe access



FLEXIBILITY

ARMS

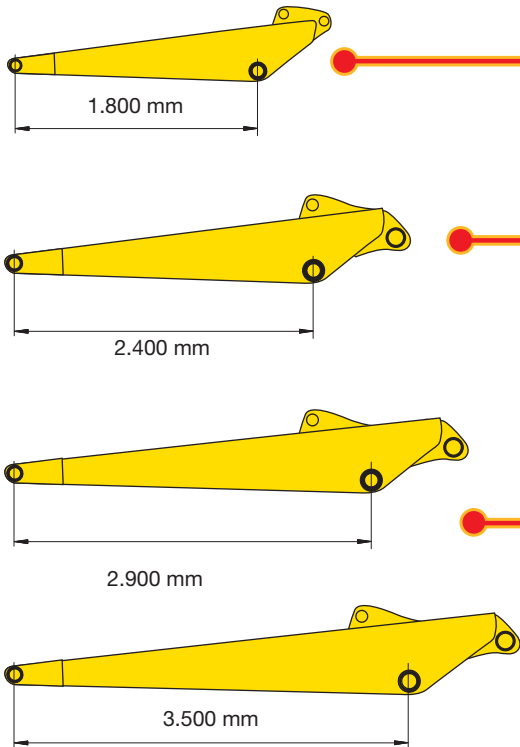

BOOMS

Mono boom

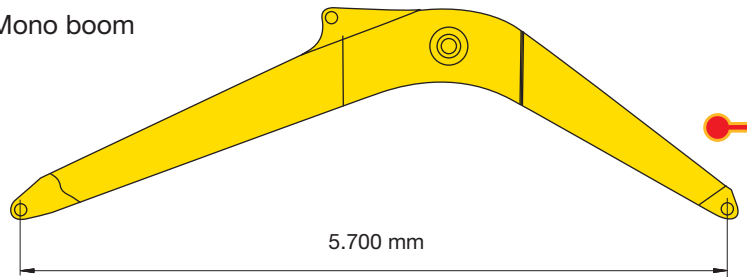

Two-piece boom

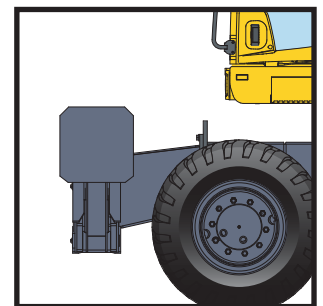
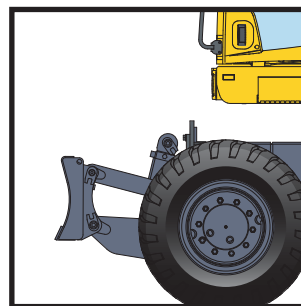
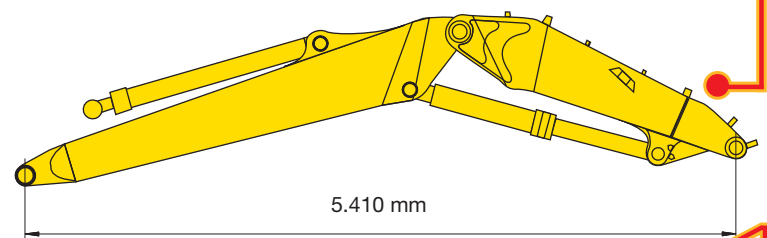

Additional hydraulic circuits

A 2-way additional hydraulic circuit, electrically controlled from the wrist control levers, is fitted as standard.



Outriggers

Independently controlled outriggers are optionally available on both, the front and rear of the machine. The cylinder protections are standard on the outriggers.

The PW200-7 can be specified with an enormous range of work equipment and undercarriage attachments to meet the needs of almost any application.

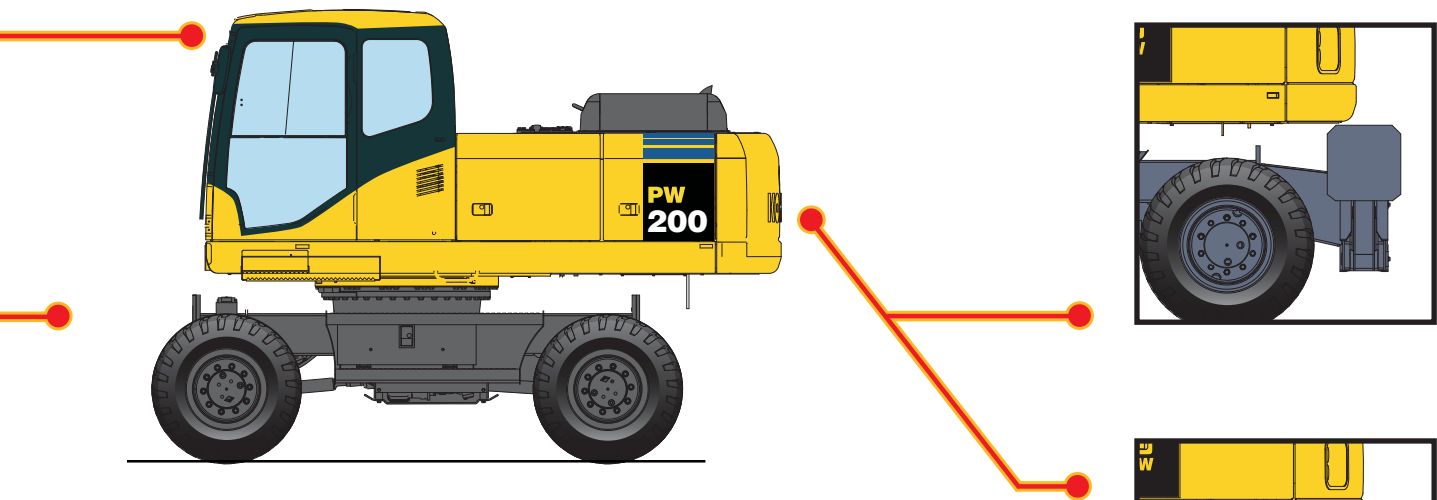

Attachments commonality & functionality

The stabilizer and dozer blade are interchangeable, and therefore can be attached on the front or rear of the chassis. The stabilizer and dozer blade are controllable from the monitor panel. The monitor panel has four buttons that allow individual attachment operation as well as collective operation.

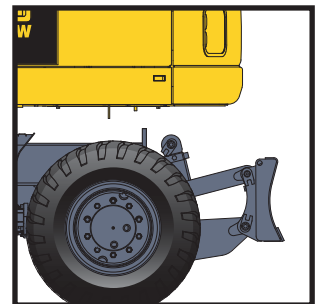
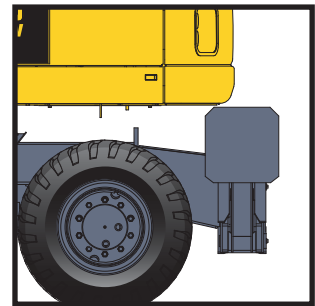

Toolbox
Tough, secure toolbox, integrated in the mudguards. Optionally fitted on both sides of the undercarriage.



Dozer blade
A parallel blade is available with standard cylinders protector for both the front and rear of the machine. Dimensions:
with 2,55 m undercarriage: 2.550 mm x 520 mm
with 2,75 m undercarriage: 2.750 mm x 520 mm

EASY OPERATION

As well as operating the standard work equipment movements, the RH wrist control lever is also used to operate the undercarriage. When used in conjunction with the selection switch on the control panel, full independent control of outriggers and dozer blade is immediately available. This feature, together with the automatic axle lock, enables the machine to be moved, stabilized and operated extremely quickly.

Breaker control

Used for breaker operation when B mode is selected.

Undercarriage attachment control

After a single touch, the lever can be used to precisely operate the selected undercarriage attachment. After operating the undercarriage attachments, a single touch reverts the lever into standard boom operation.



Clamshell control

Anti-clock wise clamshell rotation.

Travel control

A rock button is installed on the right hand lever, it controls the travel operation into forward, neutral and rear.

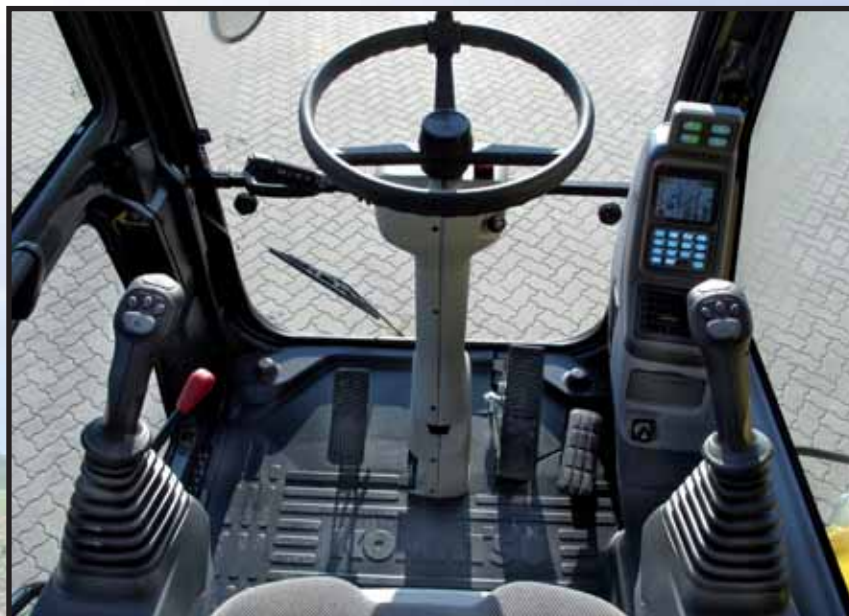

PRODUCTIVITY FEATURES



Safe and precise lifting

PW200-7's stability is one of the best in its class. The machine is equipped with boom safety valves and overload caution as standard. This combined with the control of HydrauMind and the power of the lifting mode, gives incredible safe and precise lifting performance.

Example: The over-front lifting capacity (reach 6,0 m over front, height 1,5 m) is 8,2 tonnes (outriggers front + rear, mono boom with 2,4 m arm and bucket).

Improved fuel consumption

With its newly developed Komatsu ECOT3 engine, the PW200-7 significantly reduces hourly fuel consumption through highly efficient techniques for matching the engine and hydraulic unit. The Komatsu SAA6D107E-1 engine meets EPA Tier III, and EU Stage IIIA emissions regulations and reduces NOx emissions.

PowerMax function

PowerMax can be selected by depressing a joystick button for an instant burst of power to help break through tough digging situations. The PowerMax function is available in the P and E working mode.

Bucket digging force*: 17.950 kg

Arm crowd force*: 14.800 kg

* Measured with PowerMax function, 1.800 mm arm and ISO rating



Superb visibility

Excellent all-round visibility is provided by large panoramic windows. Front visibility is further improved by the use of the Komatsu patented wiper system. When not in use the wiper parks on the cab frame itself with no contact with the front window. As well as giving excellent visibility, this systems avoids the need to disconnect the wiper before lifting the front window. The standard new plexiglas roof with sun visor gives the operator a better view of overhead obstacles and machine operations. It also allows more natural light to illuminate the cab's interior.

REVOLUTIONARY MACHINE MANAGEMENT



The Komatsu Tracking System, KOMTRAX™, provides a revolutionary new way to monitor your equipment, anytime, anywhere. It lets you pin-point the precise location of your machines and obtain real-time machine data. Using GPS location and communication satellite technology, it's designed to be future proof and will meet your demands today and tomorrow.

Komtrax will help you to answer the three most important questions you have about your machine:

- Is the machine making money
- Is the machine safe
- Is the machine in good health

For more details, please ask your distributor for a copy of the Komtrax brochure.



Check machine location



Customer



Check service meter



Annual working hour record

Caution and periodic maintenance

Working record (fuel level, hours etc.)

There are certain countries where KOMTRAX™ is not yet available, please contact your distributor when you want to activate the system. Komtrax will not operate if the satellite signal is blocked or obscured.

MAINTENANCE FEATURES

Easy maintenance

Komatsu designed the PW200-7 to have easy service access. By doing this, routine maintenance and servicing are less likely to be skipped. This can mean a reduction in costly downtime later on. Here are some of the many service features found on the PW200-7:

Easy access to the engine oil filter and fuel drain valve

The engine oil filter and fuel drain valve are mounted remotely to improve accessibility.

Side-by-side cooling

The oil cooler and radiator are installed side by side. As a result, it is very easy to clean the radiator, etc. In addition, the operator can remove and install the aftercooler, radiator and oil cooler in a short time.

Water separator

This is standard equipment which removes any water that has become mixed with the fuel, preventing fuel system damage.



Designed and built for strength

Using the latest computer aided design techniques and exhaustive testing, the boom and arm designs have been optimised for strength and durability.

The highly automated manufacturing process uses the very latest equipment and quality control techniques. Critical welding is carried out by robots to ensure an extremely high quality and consistent product.

Precision engineered pin and bush system. The key work equipment joints use a chrome plated pin and bronze bushing system to provide minimal play and extended durability.

SPECIFICATIONS



ENGINE

Model Komatsu SAA6D107E-1
 Type Common rail direct injection, water-cooled, emissionised, turbocharged, after-cooled diesel
 Engine power
 at rated engine speed 2.000 rpm
 ISO 14396 134 kW/180 HP
 ISO 9249 (net engine power) 125 kW/168 HP
 No. of cylinders 6
 Bore × stroke 107 × 124 mm
 Displacement 6,69 ltr
 Batteries 2 × 12 V/120 Ah
 Alternator 24 V/60 A
 Starter motor 24 V/5,5 kW
 Air filter type Double element type with monitor panel dust indicator and auto dust evacuator
 Cooling Suction type cooling fan



HYDRAULIC SYSTEM

Type HydraMind. Closed-centre system with load sensing and pressure compensation valves
 Additional circuits Depending on the specification up to 2 additional proportional control & 1 quick coupler circuits can be installed
 Main pump 2 variable displacement piston pumps supplying boom, arm, bucket, swing and travel circuits
 Maximum pump flow 2 × 218,4 ltr/min
 Relief valve settings
 Implement 380 bar
 Travel 380 bar
 Swing 355 bar
 Pilot circuit 37 bar



BRAKE SYSTEM

Type Dual circuit hydraulic braking system supplied from a separate gear pump.
 Service brakes Pedal actuated wet multi-disc brakes integrated into the axle hubs.
 Parking brake Electrically actuated wet multi-disc “spring actuation hydraulic release” brake integrated into the transmission.



STEERING SYSTEM

Steering control Hydraulic steering system supplied from a separate gear pump and controlled through LS orbitrol & priority valves.
 Minimum turning radius
 2,55 m wide undercarriage 6.850 mm (to center of outer wheel)
 2,75 m wide undercarriage 7.050 mm (to center of outer wheel)



SWING SYSTEM

Type Axial piston motor driving through planetary double reduction gearbox
 Swing lock Electrically actuated wet multi-disc brake integrated into swing motor.
 Swing speed 0 - 12,4 rpm
 Swing torque 68 kNm



TRANSMISSION

Type Fully automatic power shift transmission with permanent 4 wheel drive
 Travel motors One variable displacement axial piston motor
 Maximum pressure 380 bar
 Travel modes Automatic + 3 travel modes
 Max. travel speeds
 Hi / Lo / Creep 35,0 / 9,0 / 1,5 km/h
 A max. speed restriction of 20 km/h is available as an option.
 Maximum drawbar pull 12.600 kg
 Front axle load Lower than 12.000 kg
 Rear axle load Lower than 12.000 kg
 Axle oscillation 11° Lockable in any position from the operator cab.



COOLANT AND LUBRICANT CAPACITY (REFILLING)

Fuel tank 370 ltr
 Radiator 17,6 ltr
 Engine oil 25,4 ltr
 Swing drive 6,6 ltr
 Hydraulic tank 166 ltr
 Transmission 2,9 ltr
 Front differential (2,55 m wide undercarriage) 11,5 ltr
 Front differential (2,75 m wide undercarriage) 13,5 ltr
 Rear differential (2,55 m wide undercarriage) 10 ltr
 Rear differential (2,75 m wide undercarriage) 12 ltr
 Front axle hub 2,5 ltr
 Rear axle hub 2,0 ltr
 Swing pinion grease bath amount 33 ltr



ENVIRONMENT

Engine emissions Fully complies with EU Stage IIIA and EPA Tier III exhaust emission regulations
 Noise levels
 LwA external 103 dB(A) (2000/14/EC Stage II)
 LpA operator ear 72 dB(A) (ISO 6396 dynamic test)
 Vibration levels (EN 12096:1997)*
 Hand/arm ≤ 2,5 m/s² (uncertainty K = 0,275 m/s²)
 Body ≤ 0,5 m/s² (uncertainty K = 0,175 m/s²)
 * for the purpose of risk assessment under directive 2002/44/EC, please refer to ISO/TR 25398:2006.



OPERATING WEIGHT (APPR.)

Operating weight, including specified work equipment, 2.400 mm arm, operator, lubricant, coolant, full fuel tank and the standard equipment. Weights are without bucket.

UNDERCARRIAGE ATTACHMENT TYPE	MONO BOOM		TWO-PIECE BOOM	
	2,55 m undercarriage	2,75 m undercarriage	2,55 m undercarriage	2,75 m undercarriage
Undercarriage type				
Without stabilizer	18.970 kg	19.260 kg	19.650 kg	19.940 kg
Rear blade	19.850 kg	20.170 kg	20.530 kg	20.850 kg
Rear outrigger	19.980 kg	20.340 kg	20.660 kg	21.020 kg
2 outriggers + blade	20.860 kg	21.270 kg	21.540 kg	21.930 kg
4 outriggers	20.990 kg	21.420 kg	21.670 kg	22.100 kg



BUCKET OPTIONS & DIGGING FORCES

Specifications and equipment may vary according to regional availability.

BUCKET AND ARM COMBINATIONS			ARM LENGTH							
Bucket			2,55 m undercarriage				2,75 m undercarriage			
Width	Capacity (SAE)	Weight	1,8 m	2,4 m	2,9 m	3,5 m	1,8 m	2,4 m	2,9 m	3,5 m
600 mm	0,48 m ³	480 kg	○	○	○	○	○	○	○	○
700 mm	0,55 m ³	530 kg	○	○	○	○	○	○	○	○
800 mm	0,63 m ³	580 kg	○	○	○	○	○	○	○	○
900 mm	0,71 m ³	610 kg	○	○	○	○	○	○	○	○
1.000 mm	0,78 m ³	650 kg	○	○	○	□	○	○	○	○
1.100 mm	0,86 m ³	700 kg	○	○	□	△	○	○	○	○
1.200 mm	0,96 m ³	760 kg	○	○	□	△	○	○	○	□
1.300 mm	1,03 m ³	810 kg	○	□	△	-	○	○	□	△
1.400 mm	1,11 m ³	870 kg	□	△	△	-	○	□	□	△
1.500 mm	1,19 m ³	930 kg	△	△	-	-	□	□	△	-
1.600 mm	1,49 m ³	1.100 kg	-	-	-	-	□	-	-	-
1.700 mm	1,58 m ³	1.150 kg	-	-	-	-	△	-	-	-

Please consult with your distributor for the correct selection of buckets and attachments to suit the application. The recommendations are given as a guide only, based on typical operating conditions.

- Material weight up to 1,8 t/m³
- Material weight up to 1,5 t/m³
- △ Material weight up to 1,2 t/m³
- Not usable

BUCKET AND ARM FORCE				
Arm length	1.800 mm	2.400 mm	2.900 mm	3.500 mm
Bucket digging force	16.620 kg*	16.620 kg*	14.170 kg	14.170 kg
Bucket digging force at PowerMax	17.950 kg*	17.950 kg*	15.190 kg	15.190 kg
Arm crowd force	13.800 kg	12.200 kg	10.300 kg	8.500 kg
Arm crowd force at PowerMax	14.800 kg	13.000 kg	11.000 kg	9.100 kg

* With optional large bucket cylinder

DIMENSIONS

MONO BOOM

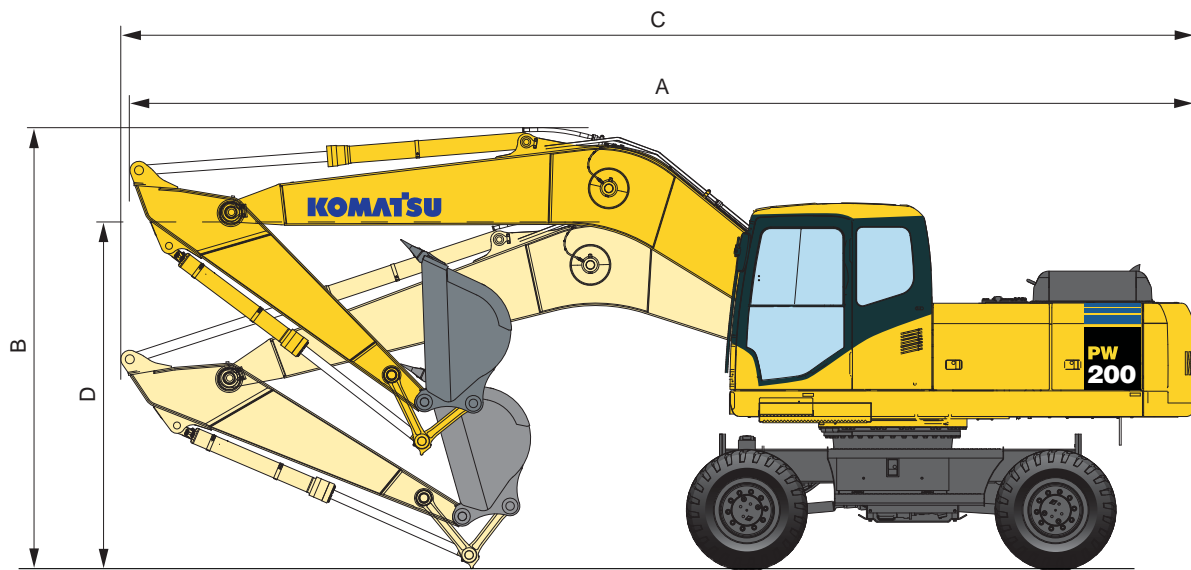

Arm length	Driving position		Transport position	
	A	B	C	D
1.800 mm	9.479 mm	3.906 mm	9.705 mm	3.266 mm
2.400 mm	9.435 mm	3.895 mm	9.659 mm	3.196 mm
2.900 mm	9.427 mm	3.912 mm	9.596 mm	3.018 mm
3.500 mm	9.467 mm	3.985 mm	9.639 mm	3.570 mm

TWO-PIECE BOOM

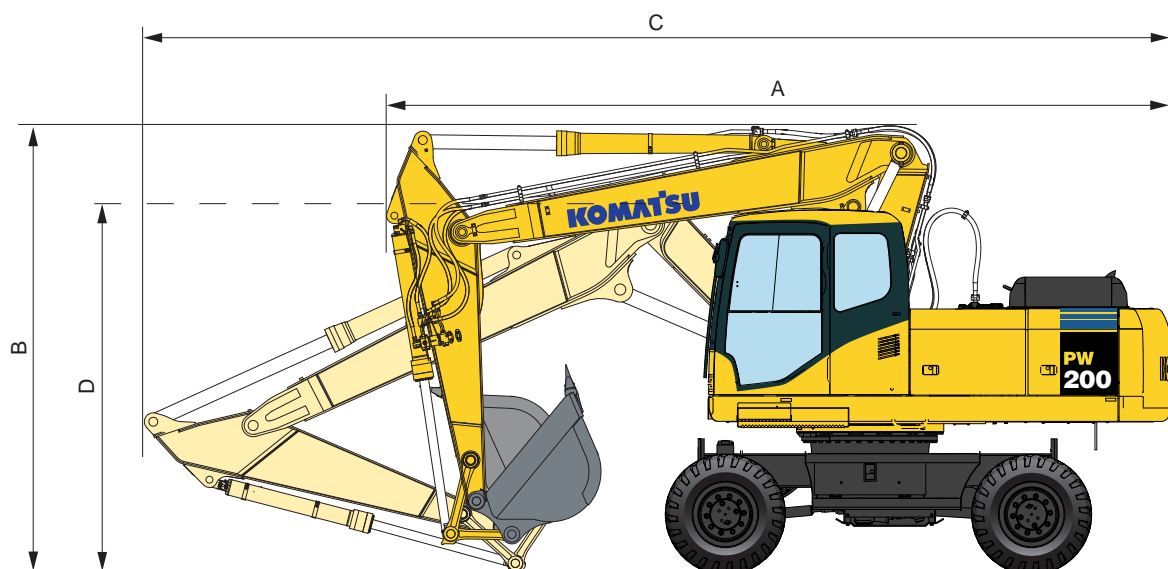

Arm length	Driving position		Transport position	
	A	B	C	D
1.800 mm	7.070 mm	3.980 mm	9.466 mm	3.040 mm
2.400 mm	7.078 mm	3.980 mm	9.470 mm	3.152 mm
2.900 mm	7.000 mm	3.997 mm	9.289 mm	3.095 mm
3.500 mm	7.218 mm	4.505 mm	9.225 mm	3.715 mm

DIMENSIONS & UNDERCARRIAGE

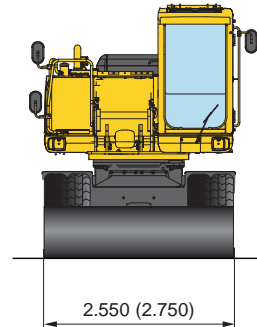
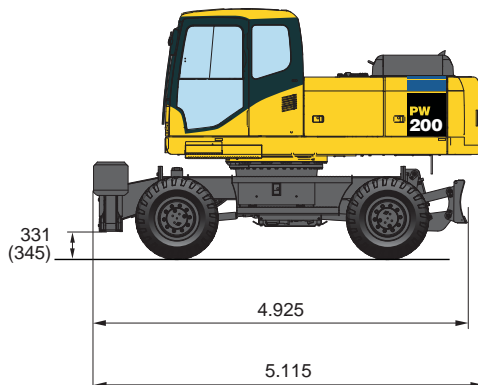
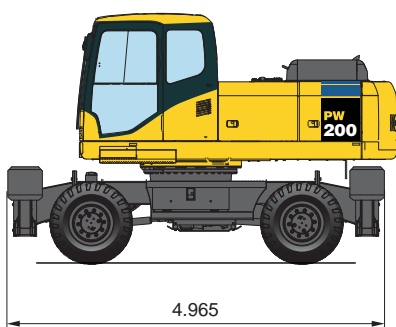
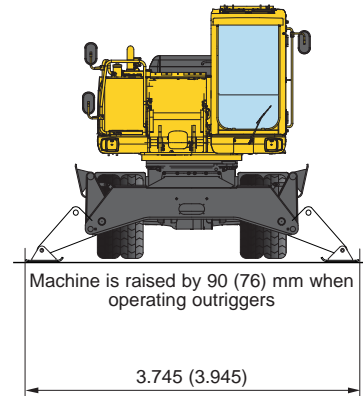
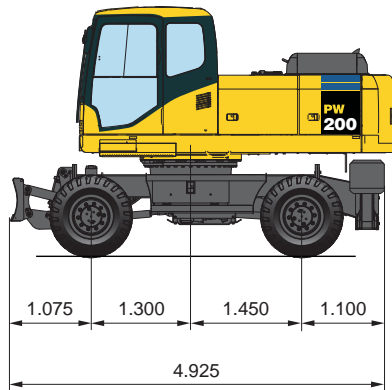
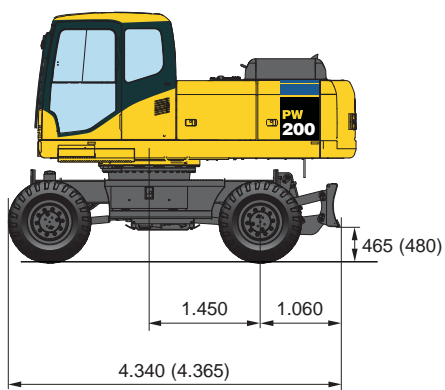
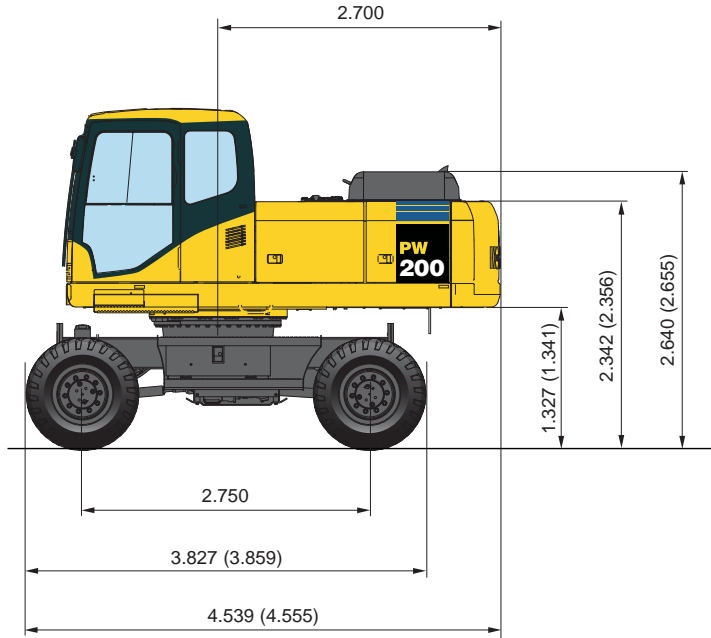
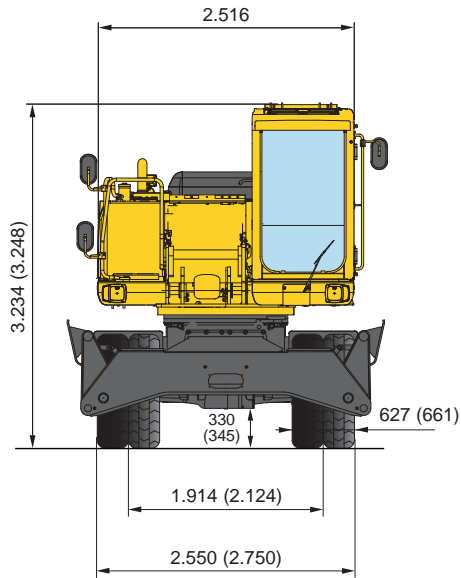

(): Figures for 2,75 m undercarriage and 11.00-20 tyres

WORKING RANGE

MONO BOOM

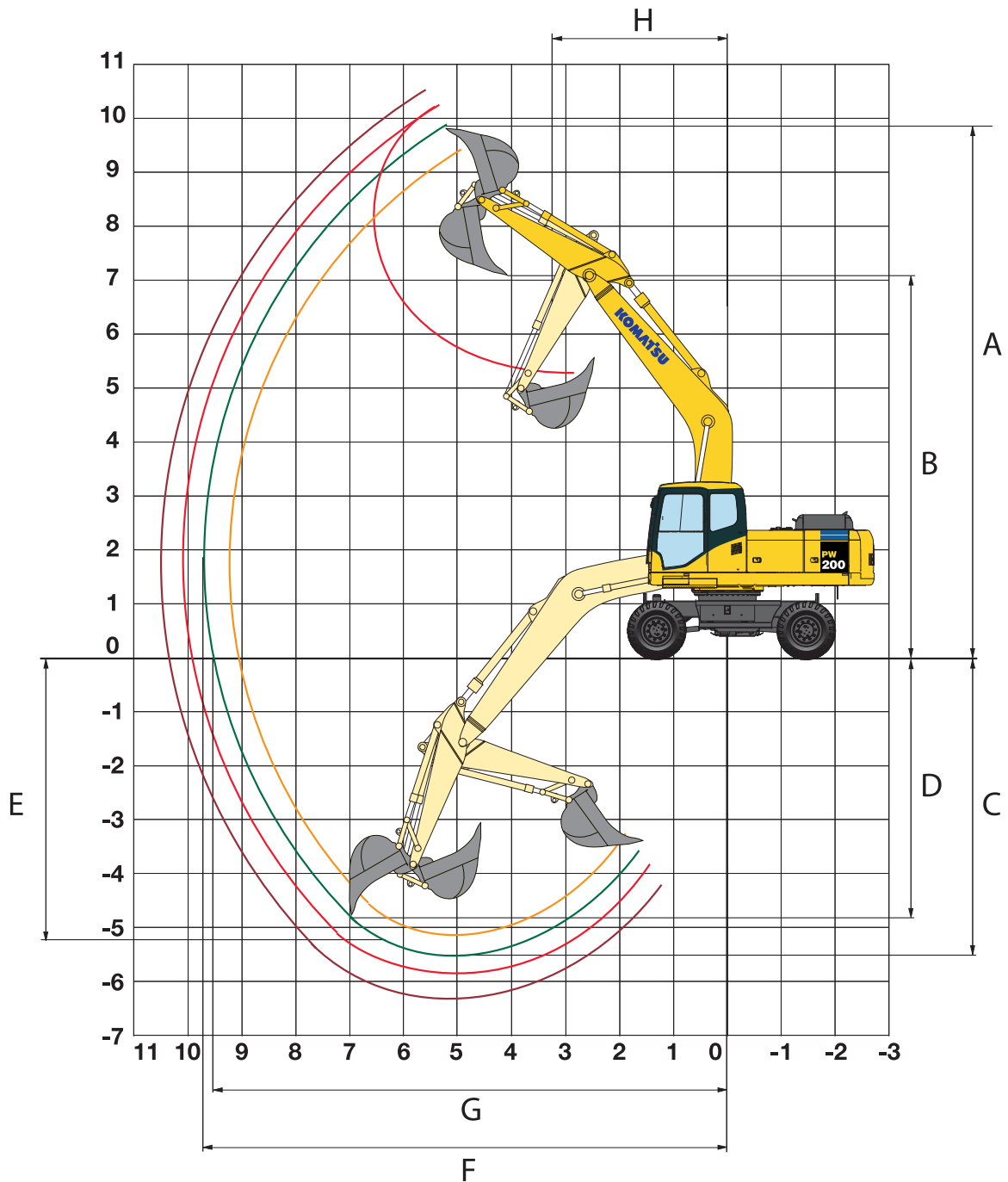

ARM LENGTH		1.800 mm	2.400 mm	2.900 mm	3.500 mm
A	Max. digging height	9.467 mm	9.883 mm	10.003 mm	10.438 mm
B	Max. dumping height	6.704 mm	7.057 mm	7.229 mm	7.612 mm
C	Max. digging depth	4.791 mm	5.402 mm	5.917 mm	6.500 mm
D	Max. vertical wall digging depth	4.141 mm	4.745 mm	5.227 mm	5.809 mm
E	Max. digging depth of cut for 2,44 m level	4.575 mm	5.225 mm	5.763 mm	6.366 mm
F	Max. digging reach	9.061 mm	9.651 mm	10.060 mm	10.642 mm
G	Max. digging reach at ground level	8.867 mm	9.438 mm	9.875 mm	10.478 mm
H	Min. swing radius	3.906 mm	3.201 mm	3.143 mm	3.148 mm

TWO-PIECE BOOM

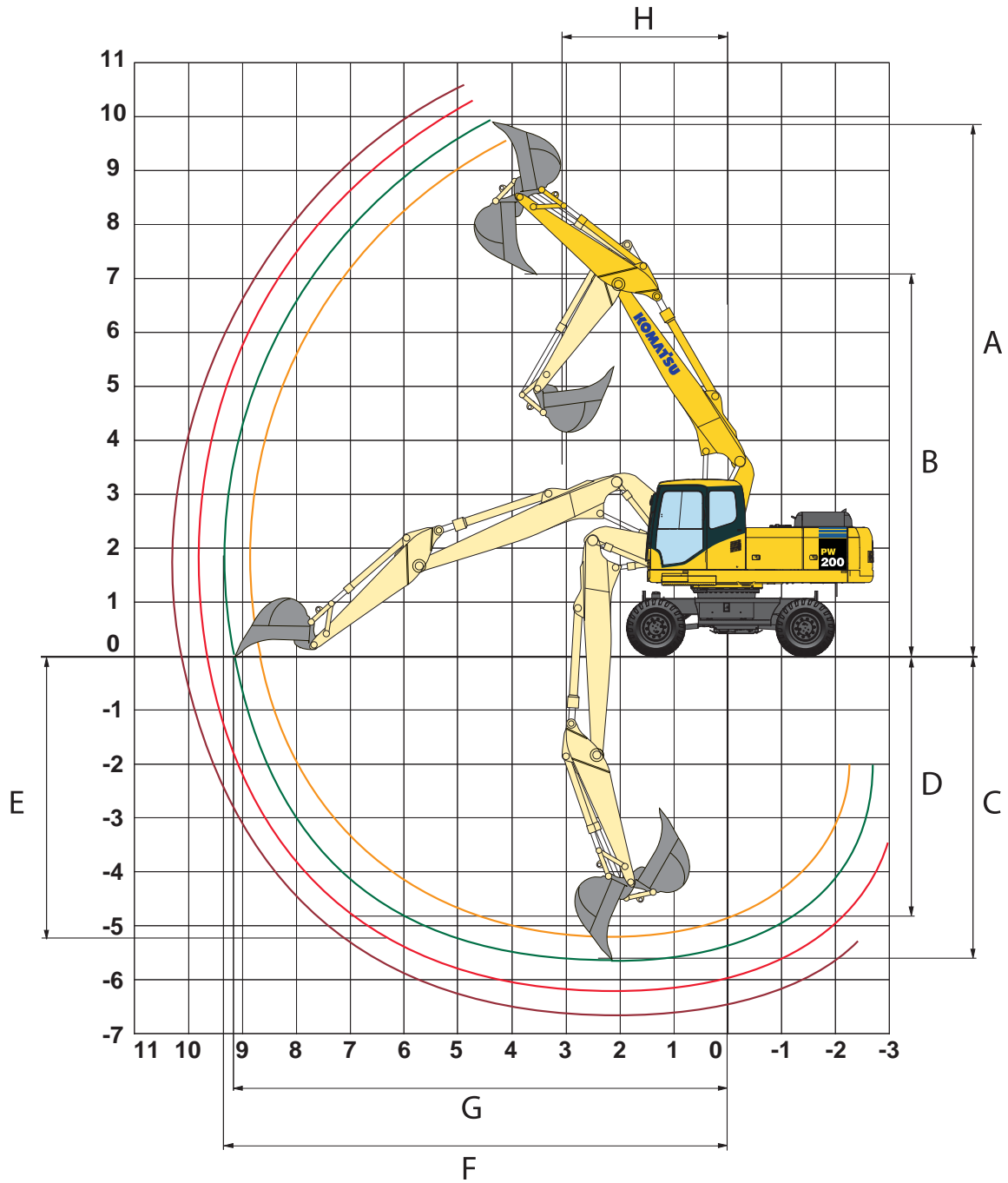

ARM LENGTH		1.800 mm	2.400 mm	2.900 mm	3.500 mm
A	Max. digging height	9.532 mm	9.842 mm	10.168 mm	10.434 mm
B	Max. dumping height	6.670 mm	6.982 mm	7.298 mm	7.574 mm
C	Max. digging depth	5.186 mm	5.785 mm	6.285 mm	6.860 mm
D	Max. vertical wall digging depth	4.104 mm	4.666 mm	5.208 mm	5.768 mm
E	Max. digging depth of cut for 2,44 m level	5.119 mm	5.713 mm	6.226 mm	6.793 mm
F	Max. digging reach	8.818 mm	9.348 mm	9.822 mm	10.338 mm
G	Max. digging reach at ground level	8.599 mm	9.144 mm	9.634 mm	10.156 mm
H	Min. swing radius	2.594 mm	3.121 mm	2.745 mm	2.866 mm

LIFTING CAPACITY

MONO BOOM

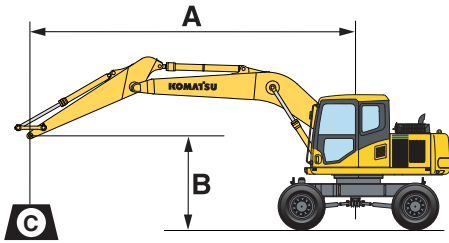

- A** – Reach from swing centre
- B** – Bucket hook height
- C** – Lifting capacities, including bucket linkage (130 kg) and bucket cylinder (182 kg)

When removing linkage or cylinder, lifting capacities can be increased by their respective weights

* Load is limited by hydraulic capacity rather than tipping.
Ratings are based on SAE Standard No. J1097.
Rated loads do not exceed 87% of hydraulic lift capacity or 75% of tipping load.

– Rating over front

– Rating over side

– Rating at maximum reach

Undercarriage width: 2,75 m

Arm length	A			9,0 m		7,5 m		6,0 m		4,5 m		3,0 m		1,5 m	

Without stabilizer	B	A			9,0 m		7,5 m		6,0 m		4,5 m		3,0 m		1,5 m	
1.800 mm	7,5 m	kg	*5.810	5.160							*7.160	6.460				
	6,0 m	kg	4.860	3.560					5.560	4.060	*7.310	6.460				
	4,5 m	kg	4.010	2.910					5.460	3.960	*8.510	6.110	*11.760	11.160		
	3,0 m	kg	3.610	2.610					5.210	3.760	7.660	5.310				
	1,5 m	kg	3.460	2.510			3.710	2.710	4.910	3.510	7.210	4.910				
	0,0 m	kg	3.560	2.560			3.560	2.560	4.710	3.310	6.960	4.660				
	-1,5 m	kg	3.910	2.810					4.660	3.260	6.910	4.660	*12.810	8.260		
-3,0 m	kg									7.110	4.810					
2.400 mm	7,5 m	kg	*5.160	4.260												
	6,0 m	kg	4.260	3.160					5.710	4.210						
	4,5 m	kg	3.610	2.660					5.560	4.110	*7.610	6.310				
	3,0 m	kg	3.310	2.410					5.260	3.860	8.110	5.710				
	1,5 m	kg	3.210	2.310			3.910	2.860	5.560	4.110	7.460	5.110				
	0,0 m	kg	3.260	2.310			3.560	2.560	4.760	3.360	7.060	4.760				
	-1,5 m	kg	3.510	2.510			3.510	2.510	4.660	3.260	6.960	4.660	*11.710	8.210		
-3,0 m	kg	4.160	2.960					4.710	3.310	7.010	4.710	*13.910	8.460			
2.900 mm	7,5 m	kg	*3.560	*3.560					*4.910	4.260						
	6,0 m	kg	*3.360	2.810					*3.960	2.910	*5.560	4.310				
	4,5 m	kg	3.310	2.410					3.960	2.910	5.660	4.160	*6.810	4.660		
	3,0 m	kg	3.010	2.210					3.810	2.810	5.360	3.910	8.310	5.910	*13.160	10.610
	1,5 m	kg	2.910	2.110					3.660	2.660	5.060	3.610	7.110	5.260	*7.110	*7.110
	0,0 m	kg	2.960	2.110					3.560	2.510	4.810	3.360	7.110	4.810	*7.710	*7.710
	-1,5 m	kg	3.160	2.260					3.460	2.460	4.610	3.210	6.910	4.610	*10.960	8.110
-3,0 m	kg	3.660	2.610					4.610	3.210	4.610	3.210	6.910	4.610	13.710	8.310	
3.500 mm	7,5 m	kg	*3.460	3.160												
	6,0 m	kg	*3.310	2.510					4.060	3.010	*4.860	4.410				
	4,5 m	kg	3.010	2.160					4.010	2.960	*5.460	3.260				
	3,0 m	kg	2.760	2.010	2.860	2.060	3.860	2.810	5.460	3.960	*7.760	6.110	*10.760	*10.760		
	1,5 m	kg	2.660	1.910	2.810	2.010	3.710	2.660	5.110	3.660	7.710	5.310				
	0,0 m	kg	2.710	1.910	2.710	1.960	3.510	2.510	4.810	3.360	7.160	4.860	*8.360	8.310		
	-1,5 m	kg	2.860	2.010			3.410	2.410	4.610	3.210	6.860	4.610	*10.460	8.060	*6.160	*6.160
-3,0 m	kg	3.210	2.260			3.410	2.410	4.560	3.110	6.810	4.510	13.460	8.110			



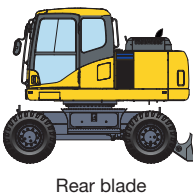

Rear blade	B	A			9,0 m		7,5 m		6,0 m		4,5 m		3,0 m		1,5 m	
1.800 mm	7,5 m	kg	*5.810	5.810							*7.160	*7.160				
	6,0 m	kg	*5.310	4.010					*6.810	4.610	*7.310	7.260				
	4,5 m	kg	*5.210	3.310					*7.160	4.510	*8.510	6.910	*11.760	*11.760		
	3,0 m	kg	*5.360	2.960					6.010	3.060	*7.910	4.260	*10.160	6.060		
	1,5 m	kg	5.610	2.860					5.910	3.010	8.310	4.010	*11.710	5.660		
	0,0 m	kg	5.810	2.910					5.810	2.910	8.060	3.810	*12.060	5.410		
	-1,5 m	kg	6.510	3.210							8.010	3.760	*11.410	5.410	*12.810	9.860
-3,0 m	kg											*9.710	5.560			
2.400 mm	7,5 m	kg	*5.160	4.760												
	6,0 m	kg	*4.860	5.560							*6.110	4.760				
	4,5 m	kg	*4.810	3.010					*6.110	3.210	*6.610	4.610	*7.610	7.110		
	3,0 m	kg	*4.960	2.710					6.110	3.160	*7.460	4.360	*9.510	6.510		
	1,5 m	kg	5.110	2.610					5.960	3.010	*8.310	4.060	*11.260	5.910		
	0,0 m	kg	5.260	2.660					5.810	2.910	8.110	3.860	*12.060	5.510		
	-1,5 m	kg	5.710	2.860					5.760	2.910	8.010	3.760	*11.860	5.410	*11.710	9.810
-3,0 m	kg	*6.760	3.410							*7.860	3.810	*10.660	5.510	*14.810	10.060	
2.900 mm	7,5 m	kg	*3.560	*3.560					*4.910	4.810						
	6,0 m	kg	*3.360	3.160					*3.960	3.310	*5.560	4.810				
	4,5 m	kg	*3.310	2.710					*5.710	3.260	*6.110	4.660	*6.810	*6.810		
	3,0 m	kg	*3.410	2.510					*6.110	3.160	*7.010	4.410	*8.710	6.710	*13.160	12.360
	1,5 m	kg	*3.660	2.410					5.960	3.010	*7.960	4.110	*10.660	6.010	*7.110	*7.110
	0,0 m	kg	*4.010	2.410					5.810	2.910	*8.160	3.860	*11.810	5.560	*7.710	*7.710
	-1,5 m	kg	*4.710	2.560					5.710	2.810	*7.960	3.710	*11.960	5.360	*10.960	9.710
-3,0 m	kg	*6.010	2.960							*7.960	3.710	*11.160	5.410	*16.010	9.910	
3.500 mm	7,5 m	kg	*3.510	*3.510												
	6,0 m	kg	*3.310	2.860					*4.710	3.410	*4.860	*4.860				
	4,5 m	kg	*3.310	2.460					*5.260	3.360	*5.460	4.760				
	3,0 m	kg	*3.410	2.260	*4.110	2.360	*5.710	3.210	*6.410	4.510	*7.760	6.910	*10.760	*10.760		
	1,5 m	kg	*3.610	2.210	4.510	2.310	5.960	3.010	*7.510	4.160	*9.810	6.110				
	0,0 m	kg	*3.960	2.210	*4.410	2.210	5.810	2.860	8.210	3.860	*11.360	5.610	*8.360	*8.360		
	-1,5 m	kg	*4.560	2.310			5.660	2.760	7.960	3.660	*11.910	5.360	*10.510	9.610	*6.160	*6.160
-3,0 m	kg	5.310	2.610			5.660	2.760	7.860	3.610	*11.510	5.260	*14.460	9.710			



Arm length	A	9,0 m		7,5 m		6,0 m		4,5 m		3,0 m		1,5 m	

 Rear outrigger	1.800 mm	7,5 m	kg	*5.810	*5.810					*7.160	*7.160			
		6,0 m	kg	*5.310	4.460			*6.810	5.110	*7.310	*7.310			
		4,5 m	kg	*5.210	3.710			*7.160	5.010	*8.510	7.710	*11.760	*11.760	
		3,0 m	kg	*5.360	3.310		6.610	3.410	*7.860	4.760	*10.160	6.860		
		1,5 m	kg	*5.810	3.210		6.510	3.310	*8.610	4.460	*11.710	6.460		
		0,0 m	kg	6.410	3.260		6.460	3.260	*8.860	4.260	*12.060	6.210		
	-1,5 m	kg	*7.060	3.610				*8.560	4.260	*11.410	6.160	12.810	11.560	
	-3,0 m	kg								*9.710	6.360			
	2.400 mm	7,5 m	kg	*5.160	*5.160					*6.110	5.260			
		6,0 m	kg	*4.860	3.960					*6.110	5.260			
		4,5 m	kg	*4.810	3.360		*6.110	3.610	*6.610	5.110	*7.610	*7.610		
		3,0 m	kg	*4.960	3.060		*6.460	3.510	*7.460	4.860	*9.510	7.310		
1,5 m		kg	*5.310	2.910		6.560	3.360	*8.310	4.560	*11.260	6.660			
0,0 m		kg	5.760	2.960		6.460	3.260	*8.810	4.360	*12.060	6.310			
-1,5 m	kg	6.360	3.210		6.410	3.210	*8.760	4.210	*11.860	6.160	*11.710	*11.510		
-3,0 m	kg	*6.760	3.810				*7.860	4.310	*10.660	6.260	*14.810	11.810		
2.900 mm	7,5 m	kg	*3.560	*3.560					*4.910	*4.910				
	6,0 m	kg	*3.360	*3.360					*4.910	*4.910				
	4,5 m	kg	*3.310	3.060		*3.960	3.660	*5.560	5.310					
	3,0 m	kg	*3.410	2.810		*5.710	3.660	*6.110	5.160	*6.810	*6.810			
	1,5 m	kg	*3.660	2.710		*6.110	3.510	*7.010	4.910	*8.710	7.510	*13.160	*13.160	
	0,0 m	kg	*4.010	2.710		*6.610	3.360	*7.960	4.610	*10.660	6.810	*7.110	*7.110	
-1,5 m	kg	*4.710	2.910		6.410	3.260	*8.660	4.360	*11.810	6.360	*7.710	*7.710		
-3,0 m	kg	*6.010	3.360		6.360	3.160	*8.760	4.160	*11.960	6.160	*10.960	*10.960		
3.500 mm	7,5 m	kg	*3.510	*3.510										
	6,0 m	kg	*3.310	3.160										
	4,5 m	kg	*3.310	2.760		*4.710	3.760	*4.860	4.860					
	3,0 m	kg	*3.410	2.560		*5.710	3.560	*6.410	5.010	*7.760	7.710	*10.760	*10.760	
	1,5 m	kg	*3.610	2.460	*4.110	2.560	*6.260	3.410	*7.510	4.660	*9.810	6.910		
	0,0 m	kg	*3.960	2.460	*4.410	2.510	6.410	3.210	*8.310	4.360	*11.360	6.410	*8.360	*8.360
-1,5 m	kg	*4.560	2.610			6.310	3.110	*8.710	4.160	*11.910	6.110	*10.510	*10.510	
-3,0 m	kg	*5.660	2.960			6.260	3.110	*8.510	4.110	*11.510	6.060	14.460	11.410	

 Outrigger + blade	1.800 mm	7,5 m	kg	*5.860	*5.860					*7.260	*7.260				
		6,0 m	kg	*5.360	*5.360					*6.910	6.360	*7.410	*7.410		
		4,5 m	kg	*5.260	4.610					*7.310	6.260	*8.660	*8.660	*11.960	*11.960
		3,0 m	kg	*5.460	4.160		6.560	4.310	*8.060	5.960	*10.310	8.910			
		1,5 m	kg	*5.860	4.010		6.460	4.210	*8.760	5.710	*11.910	8.460			
		0,0 m	kg	6.360	4.110		6.360	4.160	*8.810	5.460	*12.210	8.160			
	-1,5 m	kg	7.110	4.560				*8.710	5.460	*11.610	8.160	*13.010	*13.010		
	-3,0 m	kg								*9.910	8.360				
	2.400 mm	7,5 m	kg	*5.260	*5.260										
		6,0 m	kg	*4.910	4.910										
		4,5 m	kg	*4.860	4.160		*6.210	4.460	*6.710	6.360	*7.760	*7.760			
		3,0 m	kg	*5.010	3.810		*6.560	4.360	*7.610	6.110	*9.660	9.410			
1,5 m		kg	*5.360	3.710		6.510	4.260	*8.460	5.810	*11.410	8.710				
0,0 m		kg	5.710	3.760		6.360	4.160	*8.910	5.560	*12.210	8.310				
-1,5 m	kg	6.260	4.060		6.310	4.110	*8.760	5.410	*12.010	8.160	*11.910	*11.910			
-3,0 m	kg	*6.860	4.860				*8.010	5.510	*10.810	8.260	*15.010	*15.010			
2.900 mm	7,5 m	kg	*3.610	*3.610											
	6,0 m	kg	*3.410	*3.410											
	4,5 m	kg	*3.360	*3.360		*4.010	*4.010	*5.010	*5.010						
	3,0 m	kg	*3.460	*3.460		*5.760	4.510	*6.210	*6.210	*6.910	*6.910				
	1,5 m	kg	*3.710	3.410		*6.210	4.410	*7.110	6.160	*8.860	8.860	*13.310	*13.310		
	0,0 m	kg	*4.110	3.410		6.510	4.260	*8.060	5.860	*10.810	8.860	*7.210	*7.210		
-1,5 m	kg	*4.760	3.660		6.360	4.110	*8.760	5.560	*12.010	8.360	*7.810	*7.810			
-3,0 m	kg	*6.110	4.260		6.260	4.060	*8.710	5.410	*12.160	8.160	*11.110	*11.110			
3.500 mm	7,5 m	kg	*3.510	*3.510											
	6,0 m	kg	*3.360	*3.360											
	4,5 m	kg	*3.360	*3.360		*4.760	4.660	*4.960	*4.960						
	3,0 m	kg	*3.460	3.210		*5.310	4.610	*5.560	*5.560						
	1,5 m	kg	*3.660	3.110	*4.160	3.310	*5.810	4.460	*6.510	6.260	*7.860	*7.860	*10.910	*10.910	
	0,0 m	kg	*4.010	3.110	*4.760	3.260	*6.360	4.260	*7.610	5.910	*9.960	8.960			
-1,5 m	kg	*4.610	3.310			6.360	4.110	*8.460	5.610	*11.560	8.410	*8.460	*8.460		
-3,0 m	kg	*5.760	3.760			6.210	4.010	*8.710	5.360	*12.110	8.110	*10.610	*10.610		

 Outrigger front + rear	1.800 mm	7,5 m	kg	*5.860	*5.860					*7.260	*7.260				
		6,0 m	kg	*5.360	*5.360					*6.910	*6.910	*7.410	*7.410		
		4,5 m	kg	*5.260	*5.260					*7.310	*7.310	*8.660	*8.660	*11.960	*11.960
		3,0 m	kg	*5.460	4.860		6.710	5.060	*8.060	7.060	*10.310	*10.310			
		1,5 m	kg	*5.860	4.710		6.610	4.960	*8.760	6.760	*11.910	10.310			
		0,0 m	kg	6.510	4.860		6.560	4.860	*9.010	6.510	*12.210	10.010			
	-1,5 m	kg	7.160	5.360				*8.710	6.510	*11.610	10.010	*13.010	*13.010		
	-3,0 m	kg								*9.910	*9.910				
	2.400 mm	7,5 m	kg	*5.260	*5.260										
		6,0 m	kg	*4.910	*4.910										
		4,5 m	kg	*4.860	4.860		*6.210	5.210	*6.710	*6.710	*7.760	*7.760			
		3,0 m	kg	*5.010	4.460		*6.560	5.110	*7.610	7.160	*9.660	*9.660			
1,5 m		kg	*5.360	4.310		6.660	4.960	*8.460	6.860	*11.410	10.560				
0,0 m		kg	5.910	4.410		6.560	4.860	*8.960	6.610	*12.210	10.160				
-1,5 m	kg	6.460	4.810		6.510	4.810	*8.910	6.460	*12.010	10.010	*11.910	*11.910			
-3,0 m	kg	*6.860	5.710				*8.010	6.560	*10.810	*10.060	*15.010	*15.010			
2.900 mm	7,5 m	kg	*3.610	*3.610											
	6,0 m	kg	*3.410	*3.410											
	4,5 m	kg	*3.360	*3.360		*4.010	*4.010	*5.010	*5.010						
	3,0 m	kg	*3.460	*3.460		*5.760	5.260	*6.210	*6.210	*6.910	*6.910				
	1,5 m	kg	*3.710	*3.710		*6.210	5.010	*8.060	6.910	*10.810	10.760	*7.210	*7.210		
	0,0 m	kg	*4.110	4.010		6.510	4.860	*8.760	6.610	*12.010	10.210	*7.810	*7.810		
-1,5 m	kg	*4.760	4.310		6.460	4.760	*8.910	6.460	*12.160	9.960	*11.110	*11.110			
-3,0 m	kg	*6.110	5.010				*8.410	6.460	*11.310	9.310	*16.210	*16.210			
3.500 mm	7,5 m	kg	*3.510	*3.510											
	6,0 m	kg	*3.360	*3.360											
	4,5 m	kg	*3.360	*3.360		*4.760	*4.760	*4.960	*4.960						
	3,0 m	kg	*3.460	*3.460		*5.310	*5.310	*5.560	*5.560						
	1,5 m	kg	*3.660	3.660	*4.160	3.860	*5.810	5.210	*6.510	*6.510	*7.860	*7.860	*10.910	*10.910	
	0,0 m	kg	*4.010	3.660	*4.460	3.710	6.510	4.810	*8.460	6.660	*11.560	10.310	*8.460	*8.460	
-1,5 m	kg	*4.610	3.910			6.410	4.710	*8.860	6.460	*12.110	9.960	*10.610	*10.610		
-3,0 m	kg	*5.760	4.410			6.360	4.710	*8.610	6.360	*11.710	9.860	*14.660	*14.660		

LIFTING CAPACITY

TWO-PIECE BOOM

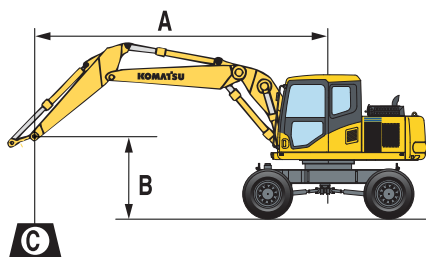

Undercarriage width: 2,55 m

- A** – Reach from swing centre
- B** – Bucket hook height
- C** – Lifting capacities, including bucket linkage (130 kg) and bucket cylinder (182 kg)

When removing linkage or cylinder, lifting capacities can be increased by their respective weights

* Load is limited by hydraulic capacity rather than tipping. Ratings are based on SAE Standard No. J1097. Rated loads do not exceed 87% of hydraulic lift capacity or 75% of tipping load.

- Rating over front
- Rating over side
- Rating at maximum reach

Arm length	A			9,0 m		7,5 m		6,0 m		4,5 m		3,0 m		1,5 m	

Without stabilizer	B	1,800 mm	7,5 m		6,0 m		4,5 m		3,0 m		1,5 m			
			kg	kg	kg	kg	kg	kg	kg	kg	kg	kg		
		1,800 mm	7,5 m	kg	*5.810	4.660					*7.160	5.760		
			6,0 m	kg	4.760	3.210			5.410	3.660	*7.310	5.810		
			4,5 m	kg	3.910	2.610			5.310	3.560	8.360	5.410	*11.760	9.760
			3,0 m	kg	3.510	2.310			5.060	3.310	7.460	4.660		
			1,5 m	kg	3.410	2.210			3.560	2.310	4.810	3.110	7.060	4.310
			0,0 m	kg	3.460	2.260			3.460	2.260	4.560	2.910	6.760	4.060
		2,400 mm	-1,5 m	kg	3.810	2.460			4.560	2.860	6.760	4.060	*12.810	7.010
			-3,0 m	kg							6.910	4.210		
			7,5 m	kg	*5.160	3.810					5.610	3.810		
			6,0 m	kg	4.210	2.810					5.460	3.660	*7.610	5.660
			4,5 m	kg	3.560	2.360			3.810	2.560	5.160	3.410	7.960	5.060
			3,0 m	kg	3.210	2.160			3.710	2.460	4.860	3.160	7.260	4.510
2,900 mm	1,5 m	kg	3.110	2.060			3.560	2.360	4.860	3.160	7.260	4.510		
	0,0 m	kg	3.160	2.060			3.460	2.260	4.660	2.960	6.860	4.160		
	-1,5 m	kg	3.410	2.210			3.460	2.210	4.660	2.960	6.760	4.060		
	-3,0 m	kg	4.060	2.610			3.460	2.210	4.610	2.910	6.810	4.110		
	7,5 m	kg	*3.560	3.260					*4.910	3.860				
	6,0 m	kg	*3.360	2.510			3.860	2.610	5.510	3.760	*6.810	5.810		
3,500 mm	4,5 m	kg	3.210	2.160			3.760	2.510	5.260	3.510	8.160	5.210		
	3,0 m	kg	2.960	1.960			3.760	2.510	5.260	3.510	8.160	5.210		
	1,5 m	kg	2.860	1.860			3.610	2.360	4.910	3.210	7.410	4.610		
	0,0 m	kg	2.860	1.860			3.460	2.210	4.660	2.960	6.910	4.160		
	-1,5 m	kg	3.060	1.960			3.360	2.160	4.510	2.810	6.710	4.010		
	-3,0 m	kg	3.560	2.260			3.360	2.160	4.510	2.810	6.710	4.010		

Rear blade	B	1,800 mm	7,5 m		6,0 m		4,5 m		3,0 m		1,5 m					
			kg	kg	kg	kg	kg	kg	kg	kg	kg	kg				
		1,800 mm	7,5 m	kg	*5.810	5.210					*7.160	6.510				
			6,0 m	kg	*5.310	3.610					*6.810	4.110	*7.310	6.510		
			4,5 m	kg	*5.210	2.960					*7.160	4.010	*8.510	6.160	*11.760	11.260
			3,0 m	kg	*5.360	2.660			5.860	2.760	*7.910	3.810	*10.160	5.360		
			1,5 m	kg	5.510	2.560			5.760	2.660	8.110	3.560	*11.710	4.960		
			0,0 m	kg	5.660	2.560			5.660	2.610	7.860	3.310	*12.060	4.710		
		2,400 mm	-1,5 m	kg	6.310	2.810					7.810	3.310	*11.410	4.710	*12.810	8.360
			-3,0 m	kg									*9.710	4.860		
			7,5 m	kg	*5.160	4.260					*6.110	4.260				
			6,0 m	kg	*4.860	3.210					*6.610	4.110	*7.610	6.360		
			4,5 m	kg	*4.810	2.710			6.060	2.910	*6.610	4.110	*7.610	6.360		
			3,0 m	kg	*4.960	2.410			5.960	2.810	*7.460	3.860	*9.510	5.760		
2,900 mm	1,5 m	kg	5.010	2.310			5.810	2.710	8.210	3.610	*11.260	5.160				
	0,0 m	kg	5.110	2.360			5.660	2.610	7.910	3.410	*12.060	4.810				
	-1,5 m	kg	5.610	2.560			5.660	2.560	7.760	3.310	*11.860	4.710	*11.710	8.310		
	-3,0 m	kg	*6.760	3.010					*7.860	3.360	*10.660	4.760	*14.810	8.560		
	7,5 m	kg	*3.560	*3.560					*4.910	4.310						
	6,0 m	kg	*3.360	2.860			*3.960	2.960	*5.560	4.360						
3,500 mm	4,5 m	kg	*3.310	2.460			*5.710	2.960	*6.110	4.210	*6.810	6.510				
	3,0 m	kg	*3.410	2.210			6.010	2.810	*7.010	3.960	*8.710	5.960	*13.160	10.710		
	1,5 m	kg	*3.660	2.110			5.810	2.710	*7.960	3.660	*10.660	5.310	*7.110	*7.110		
	0,0 m	kg	*4.010	2.160			5.660	2.560	7.960	3.410	*11.810	4.860	*7.710	*7.710		
	-1,5 m	kg	*4.710	2.260			5.560	2.510	7.760	3.260	*11.960	4.660	*10.960	8.210		
	-3,0 m	kg	5.910	2.610					7.760	3.260	*11.160	4.710	*16.010	8.410		

HYDRAULIC WHEELED EXCAVATOR

PW200-7

Arm length	A	9,0 m		7,5 m		6,0 m		4,5 m		3,0 m		1,5 m	

 Rear outrigger	1.800 mm	7,5 m	kg	*5.810	*5.810					*7.160	*7.160					
		6,0 m	kg	*5.310	4.060			*6.810	4.660	*7.310	*7.310					
		4,5 m	kg	*5.210	3.360			7.160	4.560	*8.510	7.010	*11.760	*11.760			
		3,0 m	kg	*5.360	3.010		6.460	3.110	*7.910	4.310	*10.160	6.160				
		1,5 m	kg	*5.810	2.910		6.360	3.010	*8.610	4.060	*11.710	5.760				
		0,0 m	kg	6.260	2.960		6.260	2.960	8.810	3.860	*12.060	5.510				
	-1,5 m	kg	7.010	3.260				8.560	3.810	*11.410	5.510	*12.810	10.110			
	-3,0 m	kg								*9.710	5.660					
	2.400 mm	7,5 m	kg	*5.160	4.810					*6.110	4.810					
		6,0 m	kg	*4.860	3.610					*6.110	4.810					
		4,5 m	kg	*4.810	3.060		*6.110	3.260	*6.610	4.660	*7.610	7.210				
		3,0 m	kg	*4.960	2.760		*6.460	3.210	*7.460	4.410	*9.510	6.610				
1,5 m		kg	*5.310	2.660		6.410	3.060	*8.310	4.110	*11.260	6.010					
0,0 m		kg	*5.660	2.710		6.310	2.960	*8.810	3.910	*12.060	5.610					
-1,5 m	kg	6.210	2.910		6.260	2.910	8.760	3.810	*11.860	5.510	*11.710	10.060				
-3,0 m	kg	*6.760	3.460				*7.860	3.860	*10.660	5.610	*14.810	10.310				
2.900 mm	7,5 m	kg	*3.560	*3.560					*4.910	4.860						
	6,0 m	kg	*3.360	3.210					*5.710	3.310	*6.110	4.760	*6.810			
	4,5 m	kg	*3.310	2.760		*3.960	3.360	*5.560	4.910							
	3,0 m	kg	*3.410	2.510		*6.110	3.210	*7.010	4.460	*8.710	6.810	*13.160	12.660			
	1,5 m	kg	*3.660	2.460		6.410	3.060	*7.960	4.160	*10.660	6.110	*7.110	*7.110			
	0,0 m	kg	*4.010	2.460		6.260	2.960	*8.660	3.910	*11.810	5.660	*7.710	*7.710			
-1,5 m	kg	*4.710	2.610		6.210	2.860	*8.710	3.760	*11.960	5.460	*10.960	9.960				
-3,0 m	kg	*6.010	3.010				*8.260	3.760	*11.160	5.510	*16.010	10.110				
3.500 mm	7,5 m	kg	*3.510	*3.510												
	6,0 m	kg	*3.310	2.860												
	4,5 m	kg	*3.310	2.510		*4.710	3.460	*4.860	4.860							
	3,0 m	kg	*3.410	2.310		*4.110	2.410	*5.710	3.260	*6.410	4.560	*7.760	7.010	*10.760	*10.760	
	1,5 m	kg	*3.610	2.210		*4.710	2.310	*6.260	3.060	*7.510	4.210	*9.810	6.210			
	0,0 m	kg	*3.960	2.210		*4.410	2.260	6.260	2.910	*8.310	3.910	*11.360	5.710	*8.360	*8.360	
-1,5 m	kg	*4.560	2.360				6.160	2.810	8.710	3.760	*11.910	5.460	*10.510	9.860	*6.160	*6.160
-3,0 m	kg	*5.660	2.660				6.110	2.810	*8.510	3.710	*11.510	5.360	*14.460	9.910		

 Outrigger + blade	1.800 mm	7,5 m	kg	*5.860	*5.860					*7.260	*7.260					
		6,0 m	kg	*5.360	5.210					*6.910	5.910	*7.410	*7.410			
		4,5 m	kg	*5.260	4.260					*7.310	*5.810	*8.660	*8.660	*11.960	*11.960	
		3,0 m	kg	*5.460	3.860		6.460	4.010	*8.060	5.560	*10.310	8.210				
		1,5 m	kg	*5.860	3.710		6.360	3.910	*8.760	5.260	*11.910	7.760				
		0,0 m	kg	6.260	3.810		6.260	3.810	*8.660	5.060	*12.210	7.460				
	-1,5 m	kg	6.960	4.210				8.660	5.010	*11.610	7.460	*13.010	*13.010			
	-3,0 m	kg								*9.910	7.610					
	2.400 mm	7,5 m	kg	*5.260	*5.260											
		6,0 m	kg	*4.910	4.560					*6.210	6.060					
		4,5 m	kg	*4.860	3.860		*6.210	4.160	*6.710	5.910	*7.760	*7.760				
		3,0 m	kg	*5.010	3.560		6.510	4.060	*7.610	5.660	*9.660	8.660				
1,5 m		kg	*5.360	3.410		6.360	3.910	*8.460	5.360	*11.410	7.960					
0,0 m		kg	5.610	3.460		6.260	3.810	*8.760	5.110	*12.210	7.610					
-1,5 m	kg	6.160	3.760		6.210	3.810	8.610	5.010	*12.010	7.460	*11.910	*11.910				
-3,0 m	kg	*6.860	4.460				*8.010	5.060	*10.810	7.560	*15.010	*15.010				
2.900 mm	7,5 m	kg	*3.610	*3.610					*5.010	*5.010						
	6,0 m	kg	*3.410	*3.410					*5.610	*5.610						
	4,5 m	kg	*3.360	*3.360		*5.760	4.210	*6.210	6.010	*6.910	*6.910					
	3,0 m	kg	*3.460	3.260		*6.210	4.110	*7.110	5.710	*8.860	8.860	*13.310	*13.310			
	1,5 m	kg	*3.710	3.160		6.410	3.960	*8.060	5.410	*10.810	8.110	*7.210	*7.210			
	0,0 m	kg	*4.110	3.160		6.260	3.810	*8.760	5.160	*12.010	7.660	*7.810	*7.810			
-1,5 m	kg	*4.760	3.410		6.160	3.760	8.560	4.960	*12.160	7.460	*11.110	*11.110				
-3,0 m	kg	*6.110	3.910				*8.410	4.960	*11.310	7.460	*16.210	*14.810				
3.500 mm	7,5 m	kg	*3.510	*3.510												
	6,0 m	kg	*3.360	*3.360												
	4,5 m	kg	*3.360	3.210		*5.310	4.260	*5.560	*5.560							
	3,0 m	kg	*3.460	2.960		*4.160	3.060	*5.810	4.110	*6.510	5.810	*7.860	*7.860	*10.910	*10.910	
	1,5 m	kg	*3.660	2.860		*4.760	3.010	*6.360	3.960	*7.610	5.460	*9.960	8.260			
	0,0 m	kg	*4.010	2.910		*4.460	2.960	6.260	3.810	*8.460	5.160	*11.560	7.710	*8.460	*8.460	
-1,5 m	kg	*4.610	3.060				6.110	3.660	8.560	4.960	*12.110	7.410	*10.610	*10.610	*6.260	*6.260
-3,0 m	kg	5.710	3.460				6.110	3.660	8.510	4.910	*11.710	7.310	*14.660	*14.660		

 Outrigger front + rear	1.800 mm	7,5 m	kg	*5.860	*5.860					*7.260	*7.260					
		6,0 m	kg	*5.360	*5.360					*6.910	*6.910	*7.410	*7.410			
		4,5 m	kg	*5.260	5.110					*7.310	6.960	*8.660	*8.660	*11.960	*11.960	
		3,0 m	kg	*5.460	4.610		6.610	4.760	*8.060	6.660	*10.310	10.160				
		1,5 m	kg	*5.860	4.460		6.460	4.660	*8.760	6.410	*11.910	9.660				
		0,0 m	kg	6.410	4.560		6.410	4.610	8.860	6.160	*12.210	9.360				
	-1,5 m	kg	7.160	5.060				8.710	6.110	*11.610	9.360	*13.010	*13.010			
	-3,0 m	kg								*9.910	9.510					
	2.400 mm	7,5 m	kg	*5.260	*5.260											
		6,0 m	kg	*4.910	*4.910					*6.210	*6.210					
		4,5 m	kg	*4.860	4.610					*6.210	*6.210	*7.760	*7.760			
		3,0 m	kg	*5.010	4.210		*6.560	4.860	*7.610	6.760	*9.660	*9.660				
1,5 m		kg	*5.360	4.060		6.510	4.710	*8.460	6.460	*11.410	9.910					
0,0 m		kg	5.760	4.160		6.410	4.610	*8.960	6.210	*12.210	9.510					
-1,5 m	kg	6.310	4.510		6.360	4.560	8.810	6.110	*12.010	9.360	*11.910	*11.910				
-3,0 m	kg	*6.860	5.410				*8.010	6.160	*10.810	9.460	*15.010	*15.010				
2.900 mm	7,5 m	kg	*3.610	*3.610					*5.010	*5.010						
	6,0 m	kg	*3.410	*3.410					*5.610	*5.610						
	4,5 m	kg	*3.360	*3.360		*5.760	5.010	*6.210	*6.210	*6.910	*6.910					
	3,0 m	kg	*3.460	*3.460		*6.210	4.860	*7.110	6.860	*8.860	*8.860	*13.310	*13.310			
	1,5 m	kg	*3.710	*3.710		6.560	4.710	*8.060	6.510	*10.810	10.060	*7.210	*7.210			
	0,0 m	kg	*4.110	3.810		6.410	4.560	*8.760	6.260	*12.010	9.560	*7.810	*7.810			
-1,5 m	kg	*4.760	4.110		6.310	4.510	8.760	6.060	*12.160	9.310	*11.110	*11.110				
-3,0 m	kg	*6.110	4.760				*8.410	6.060	*11.310	9.310	*16.210	*16.210				
3.500 mm	7,5 m	kg	*3.510	*3.510												
	6,0 m	kg	*3.360	*3.360												
	4,5 m	kg	*3.360	*3.360		*5.310	5.060	*5.560	*5.560							
	3,0 m	kg	*3.460	*3.460		*4.160	3.660	*5.810	4.910	*6.510	*6.510	*7.860	*7.860	*10.910	*10.910	
	1,5 m	kg	*3.660	3.460		*4.760	3.610	*6.360	4.710	*7.610	6.610	*9.960	*9.960			
	0,0 m	kg	*4.010	3.460		*4.460	3.510	6.360	4.560	*8.460	6.260	*11.560	9.660	*8.460	*8.460	
-1,5 m	kg	*4.610	3.710				6.260	4.460	8.810	6.060	*12.110	9.310	*10.610	*10.610	*6.260	*6.260
-3,0 m	kg	*5.760	4.160				6.260	4.410	*8.610	6.010	*11.710	9.210	*14.660	*14.660		

HYDRAULIC WHEELED EXCAVATOR

STANDARD EQUIPMENT

- Komatsu SAA6D107E-1, 134 kW turbocharged common rail direct injection diesel engine, EU Stage IIIA compliant
- Double element type air cleaner with dust indicator and auto dust evacuator
- Suction type cooling fan
- Automatic fuel line de-aeration
- Engine key stop
- Engine ignition can be password secured on request
- Engine overheat prevention system
- Auto-deceleration function
- Automatic engine warm-up system
- Alternator 24 V/60 A
- Batteries 2 × 12 V/120 Ah
- Starter motor 24 V/5,5 kW
- Standard counterweight
- Electronic closed-centre load sensing (E-CLSS) hydraulic system (HydrauMind)
- Pump and engine mutual control (PEMC) system
- Multi-function colour monitor with equipment management monitoring system (EMMS)
- 4-working mode selection system; Power mode, economy mode, breaker mode and lifting mode
- PowerMax function
- Adjustable PPC wrist control levers with 3 button control and proportional attachment control slider for arm, boom, bucket and swing
- Additional hydraulic circuit (HCU-B)
- Fully automatic 3-speed transmission driving through front and rear planetary axles
- Orbitrol type hydraulic steering acting on front wheels
- Oscillating front axle (11°) with automatic and manual cylinder locking
- Dual circuit hydraulic brakes with outboard wet multi-disc service brakes
- Spring actuated park brake (hydraulic release) incorporated into transmission
- SpaceCab™, highly pressurized and tightly sealed viscous mounted cab with tinted safety glass windows, pull-up type front window with locking device, heated rear window, removable lower window, front window wiper with intermittent feature, sun blind roller, magazine rack behind seat, 12 V power supply, cigarette lighter, ashtray, floor mat, machine cab handrails, suspension seat with tiltable left hand console, automatic weight adjustment, adjustable arm rests and retractable seat belt, hot and cool box
- KOMTRAX™ Komatsu Tracking System
- Parts book and operator manual
- Lockable fuel cap and covers
- Fuel supply pump
- Overload warning device
- Boom safety valves
- Dozer blade cylinder guard
- Climate control/Air conditioning
- Centralised greasing system
- Radio cassette preparation
- Toolkit and spare parts for first service
- Single chassis tool box
- Standard colour scheme and decals
- 2,55 m wide undercarriage

OPTIONAL EQUIPMENT

- Mono boom
- Two-piece boom
- 2,4 m; 2,9 m; 3,5 m arms
- 2,75 m wide undercarriage
- Additional hydraulic circuit (HCU-C)
- Parallel blade (front and/or rear)
- 2 or 4 outriggers with cylinder protection (front and/or rear)
- Large bore bucket cylinders (2,4 m arms only)
- Four sets of tyre and rim (twin tyre) 10.00-20 14 PR
- Four sets of tyre and rim (twin tyre) 11.00-20 16 PR
- Four sets of tyre and rim (single tyre) 18.00 R22
- Nokian twin tyres 10-20
- Nokian twin tyres 11-20
- Clean fix fan (with turning blades for cleaning function)
- Turbo II pre-cleaner
- Automatic greasing system
- Quick-coupler piping
- Komatsu quick couplers
- Komatsu buckets
- Transmission guard
- Clamshell grip bar
- Adjust cylinder safety valve
- Arm cylinder safety valve
- Heated air suspension seat
- Radio-cassette
- Lower wiper
- OPG Level II front guard (FOPS)
- OPG Level II top guard (FOPS)
- Additional RH boom lamp
- Beacon + rear facing cab lamp
- 1 or 2 additional beacons on counterweight
- Additional large capacity cab roof lights (2)
- Xenon working lights
- Optical back-up alarm (blue or white strobe light)
- Super tone horn (no road approval)
- Back-up alarm (white noise version)
- Bio oil
- Rain visor (not for use with OPG)
- Additional chassis tool box
- Customized paint



**Komatsu Europe
International NV**

Mechelsesteenweg 586
B-1800 VILVOORDE (BELGIUM)
Tel. +32-2-255 24 11
Fax +32-2-252 19 81
www.komatsu.eu

VESS001803 02/2012

Materials and specifications are subject to change without notice.

KOMATSU is a trademark of Komatsu Ltd. Japan.

APPENDIX C

PLATES



Plate C-01 – Looking west from Windmill Hill Road.



Plate C-02 – Looking south from Windmill Hill Road.



Plate C-03 – Looking south from Windmill Hill Road.



Plate C-04 – Looking east from Lathbury Barracks.



Plate C-05 – Looking north from Lathbury Barracks.

APPENDIX D

DESIGNER'S RISK ASSESSMENTS

Project Title DEMOLITION OF THE LATHBURY BARRACKS WATCH TOWER		HEALTH & SAFETY RISK ASSESSMENT / ACTION PLAN						Sheet No. 1	
								Date: 15 April 2014	
Designer: CIVIL & STRUCTURAL ENGINEERS								Prepared by: JJD	
Activity / Element	Potential Hazard	People at Risk			Risk Rating			Control Measures Required During Site Work	Action Required at Design Stage
		Wkr	Vis	Pub	Sev	Freq	O/A		
Demolition / dismantling / stripping out / structural alterations - roof timber rafters / trusses; - masonry / random rubble load bearing walls; - steel beams; - reinforced concrete floors;	Live Services	√			M	L	M	Adequate method statement. Mark out the services on on site and make services safe. Suitable equipment / training and safe system of work. Obtain Service Clearances.	Adequate survey. Provide adequate information noting any nature and location of known live services.
	Uncontrolled Collapse / Over loading	√		√	M	L	L	Adequate method statement – comply with the Struct. Eng's report. Suitable sequences of work. Adequate protection /temporary support to retained structure and adjoining properties where necessary. Site fencing to cordon off site from public areas – including safety buffer zone.	Adequate survey. Provide structural report noting principles of structural stability, demolition methodology and any special hazards inherent in the existing construction or adjoining properties. Obtain demolition permit from Building Control.
	Falls from height	√			H	M	M	Adequate method statement. Suitable equipment/training and safe system of work including use of scaffolds, etc.. where possible.	Avoid unnecessary demolition and the specification of complex or hazardous demolition sequences.
	Hazardous Materials / Substances	√			M	L	L	Adequate method statement. Adequate inspection/testing. Suitable equipment/training and safe system of work.	Adequate survey/testing. Provide adequate information noting any hazardous material/substances.
	Work with Asbestos	√			L	L	L	Licensed contractor. Adequate method statement adopting safe systems of work and site controls complying with asbestos Regs. Statutory notification.	Adequate investigation/ testing (by specialist). Provide adequate information at tender stage.
	Dust	P	P		M	L	M	Adequate method statement. Adequate site controls.	Specify any special requirements.
	Noise / Vibrations	P	P		M	L	M	Adopt low noise techniques/plant where reasonably practicable. Adequate method statement / site controls.	Consider existing / surrounding premises and their occupants. Specify any noise or vibration restrictions.
	Fire / Explosion	P			L	L	L	Adequate method statement. Adequate site controls.	Identify any record presence of any live gas/pipes, fuel tanks/supplies etc. Provide adequate tender information.

Activity / Element		Potential Hazard	People at Risk			Risk Rating			Control Measures Required During Site Work	Action Required at Design Stage
			Wkr	Vis	Pub	Sev	Freq	O/A		
Project Title DEMOLITION OF THE LATHBURY BARRACKS WATCH TOWER		HEALTH & SAFETY RISK ASSESSMENT / ACTION PLAN							Sheet No. 2	
Designer: CIVIL & STRUCTURAL ENGINEERS									Date: 15 April 2014	
Debris falling onto public areas.		Hit by debris.	√	√	√	M	L	M	Provide debris netting and erect fencing around the perimeter of building to be demolished.	Consider scaffolding protection around the building in the method statement.
Construction traffic accessing the site.		Traffic accident / injury to pedestrians.		√	√	M	L	M	Provide traffic management arrangement – allow for congested pedestrian and vehicular traffic on the adjacent public highway, Windmill Hill Road.	Highlight to the contractor the hazards in the structural report.
Damage / Injury to public on adjacent highway and walkway.		General injury.		√	√	M	L	M	Implement exclusion zone and provide continuous and interrupted supervision. Consider traffic management arrangements during demolition works adjacent to the highway i.e. divert traffic and pedestrians during critical demolition works. Consider carrying out critical demolition works at night time when there is less traffic.	Highlight to the contractor the hazards in the structural report and recommend stringent implementation of the exclusion zones and traffic management arrangements.
Damage to adjacent structures..		Damage.	√	√	√	M	L	M	Protect and separate existing structures from the demolition works.	Carry out survey of surrounding area. Highlight adjacent structures in the structural demolition report and include means of separating existing structures from the demolition by manual methods.
Notes		Key: √ - definitely at risk P - possibly at risk			Key: H – high M – medium L - low			Notes		

APPENDIX E

TRAFFIC MANAGEMENT PLAN

